

Highly Efficient Battery Storage Systems Are Necessary to Master the Energy Transition in an Economically Acceptable Way.



## The Lithium-ion Storage System



Compact lithium-ion storage system in the research environment at KIT

This large-scale lithium-ion storage system was developed at KIT on the basis of components available in the industry. Nevertheless, it offers a multitude of innovations, which can contribute to increasing economic efficiency and thus to spreading battery storage devices in various fields of application.

Particularly important for the design of the storage system were its safety and energy efficiency. In particular, propagation-proof battery packs and the spatial separation of the battery from the power electronics greatly limits the consequences in the case of a fire. This allows the storage system to be installed even in sensitive environments.

### Cooling Concept

The idea behind the cooling concept is the indirect water cooling of the battery modules. The battery modules are positioned directly on the tubes of the cooling circuit. The heat losses of the Li-ion cells and the battery management system are transferred directly to the coolant. Boreholes for transferring the heat to the groundwater are part of the cooling circuit. Compared to conventional systems, this system significantly reduces the energy required for cooling the battery storage system.

View into the battery room:  
Battery modules (white), shelving system,  
and copper cooling pipes.





# The Lithium-ion Storage System

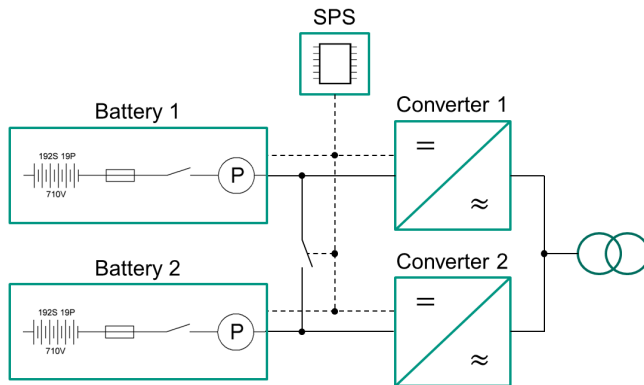

Scheme of the operating concept

## Technical Data and Operating Concept

The storage system supplies 1.5 MWh of energy and consists of 608 battery modules. With a nominal DC voltage of 710 V, up to 800 kW of electrical power can be achieved. The interconnection of two independent battery and converter systems offers important advantages. The storage system continues if a component fails: A special partial-load operating mode increases the service life and overall efficiency.

## Interaction with Other Energy Lab Facilities

Since 2013, the Battery Technical Center at KIT has been operating several storage systems from 30 kWh to 75 kWh. These storage systems are used in the development of battery storage control systems and for implementation and design of various operating strategies. On this basis, a near-series prototype of a lithium-ion storage system was developed and installed at the photovoltaic facility of KIT as part of the Energy Lab 2.0. The thermal component activation of the concrete building and the use of the groundwater for temperature control of the batteries allow minimization of the

operating and maintenance costs of the system and ensure a long lifespan. The space required for the storage systems is reduced by proportional sinking of the building into the ground. The acceptance of the building as a storage facility in residential areas is enhanced by the attractive design.

The robust building and a smart safety system also makes the system suitable for installation under unfavourable weather and adverse environmental conditions. The hardware, if equipped with the appropriate software packages, is suitable for variable applications. This includes the primary operating reserve to compensate volatile-generated (i. e., time-, location- and weather-dependent) electrical energy or industrial applications (compensation of peak loads). The storage system is scalable in its rated power and storage capacity. Therefore, various requirements can be met.



Michael Mast  
Institute of Electrical Engineering (ETI)  
Battery Technology Center  
Karlsruhe Institute of Technology

Hermann-von-Helmholtz-Platz 1  
76344 Eggenstein-Leopoldshafen

michael.mast@kit.edu